

CE COMPLIANCE STATEMENT

The HT900 series transceiver displays "CE" on the serial number label, indicating its compliance with the essential requirements of the EEC directive for Electromagnetic Compatibility.

DECLARATION OF CONFORMITY

We Entel UK Limited,

OF:
4 Elstree Gate, Elstree Way
Borehamwood, Herts
WD6 1JD
United Kingdom

Declare under our sole responsibility that the product:-
HT900 series VHF/UHF handheld transceiver

Serial Number

To which this declaration relates, is in accordance with directive 95/5/EC and conforms to the following standard or other nominative documents:-
EN 300 086-2 V1.1.1, EN 301 489-1 V1.5.1:2003, EN 60065:2002
Following provisions of the R&TTE directive.

And

Directive 94/9/EC (ATEX)

Notified Body 0539

Standards:-

UL International Demko A/S

EN 50014:1997

Lyskaer 8, 2730 Herlev, Demnark.

EN 50020:2002

Certificate number DEMKO 03ATEX136181

M. Austin.

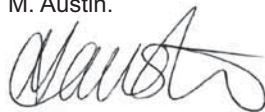

Quality Manager



TABLE OF CONTENTS

1.1 GENERAL FEATURES	04
1.2 PACKING LIST	04
1.3 OPTIONS (ACCESSORIES)	05
1.3.1 ATTACHING AUDIO ACCESSORIES	06
1.4 CONTROLS AND INDICATORS	09
1.5 LCD INDICATORS	10
1.6 RECEPTION	11
1.7 TRANSMITTING	11
1.8 ADDITIONAL FEATURES	12
1.9 VOX (voice operated transmit)	12
2.0 OPTIONAL TRICKLE CHARGER-model CCA230	13
2.1 OPTIONAL CHARGER-model CSA640E	13
2.2 BATTERY INDICATOR	14
2.3 BATTERY SAFETY	15
2.4 TROUBLE SHOOTING	16
2.5 SPECIFICATION (General, receive and transmit)	17
2.6 SAFETY TRAINING INFORMATION	20
2.7 NOTES	22

1.1 GENERAL FEATURES

1. ATEX approved intrinsically safe
2. Heavy duty, commercial grade construction
3. Submersible / Fully waterproof to IP67
4. 128 PC programmable channels
5. All CTCSS & DCS tones
6. Scan mode
7. Five programmable buttons
8. Lithium-Ion battery technology
9. 14 hour duty cycle
10. VOX (voice operated transmit)
11. Low battery warning bleep
12. Battery level indicator
13. Extensive range of accessories

1.2 PACKING LIST

The supplied package: (ATEX approved intrinsically safe)

- ▶ HT920/980 Transceiver
- ▶ CNB940E 1800mAh rechargeable lithium-Ion battery pack
- ▶ CBH940 Spring loaded rear clip
- ▶ CAT20/80 High efficiency antenna
- ▶ Owner's manual

1.3 OPTIONAL ACCESSORIES (ATEX APPROVED)

The HT900 Series is supported by a wide range of useful accessories.
For an up to date list visit our web site at www.entel.co.uk

CSA640E	Single pod intelligent rapid charger, 110/230v operation
CSB640E	Six pod intelligent rapid charger, 110/230v operation
CCA230	230v drop in trickle charger. (Also available as 110v -CCA110)
CCA12	12v drop in trickle charger complete with cigar lighter lead.
CNB940E	7.4V 1800mAh rechargeable lithium-Ion battery pack, with rear clip

Note: DO NOT CHARGE OR REMOVE THE BATTERY PACK IN THE
HAZARDOUS AREA LOCATION.

CMP940	Submersible, noise cancelling speaker microphone (heavy duty)
EA12/940	D Shape earpiece microphone with PTT button
EA15/940	Covert style ear/microphone with transparent acoustic tube
EA19/940	Earpiece microphone with PTT button
EPT40/940	Bone conductive earpiece microphone
CHP940/HD	Heavy duty double ear defender for hardhat with PTT (vox)
CHP940/HS	Heavy duty single ear defender for hardhat and PTT (vox)
CHP940D	Heavy duty double ear defender with headband and PTT (vox)
CXR5/940	Skull microphone
CXR16/940	Throat microphone
CLC940	Heavy duty leather case with belt loop & carry strap
CXW640	Antenna adaptor for external aerial connection
CAT20VS	Stubby antenna VHF
CAT80US	Stubby antenna UHF
CAT20	High efficiency antenna, VHF
CAT80	High efficiency antenna, UHF
CBH940	Spring loaded rear clip

Note: THE USE OF NON ENTEL APPROVED ACCESSORIES WILL
INVALIDATE YOUR ATEX INTRINSICALLY SAFE APPROVAL

Accessories suitable for vox operation have been marked (vox)

1.3.1 ATTACHING AUDIO ACCESSORIES

Locate accessory connector cover marked "ACC" Lift cover and rotate (screw) the connector clockwise.

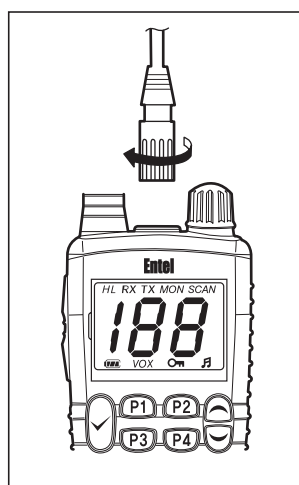

Note: The accessory socket is waterproof without the ACC cover in place. However, when not using an audio accessory we strongly advise keeping the ACC cover firmly pressed in its recess to prevent foreign objects from getting into the socket.

Figure 1. Attaching the accessory connector

Preparation prior to use

1. Attaching the belt clip; Align the belt clip with the plastic slots of the battery pack. Slide the belt clip downwards onto the battery pack, pushing firmly until a click is heard.

2. BATTERY REMOVAL/ATTACHMENT

1. Turn the transceiver off.
2. Using a coin, rotate the battery screw anti-clockwise 2 or 3 turns.
**Ensure that you do not hold the battery pack when unscrewing the release screw!

3. To attach the battery: firstly, place the battery against the bottom of the radio, then hinge the battery into place against the transceiver. Rotate the battery locking screw clockwise taking care not to over tighten the screw.

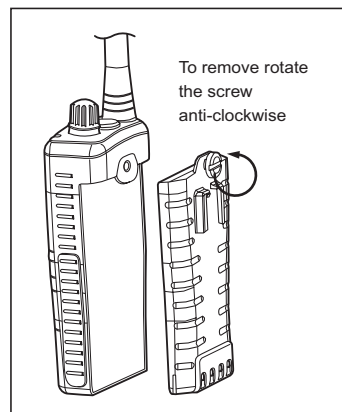

Figure 2.

Battery removal / Attachment

1.4 CONTROLS AND INDICATORS

1. POWER SWITCH/VOLUME CONTROL

Rotate clockwise to power the transceiver on and increase received volume. Rotate anticlockwise to reduce received volume and switch off.

2. PUSH TO TALK SWITCH

Hold down to transmit, release to receive.

3. UP/DOWN button

Select the desired channel by pressing the UP/DOWN buttons. For fast channel selection hold down for more than 1 second.

4. LAMP/LOCK button

Momentarily press to turn backlight on/off. Press and hold to turn backlight on / off. Press and hold to turn monitor on / off.

5. P1, P2, P3, P4 buttons

Dealer programmable.

6. ✓ button

Dealer programmable.

7. MON buttons

Dealer programmable.

8. ANTENNA CONNECTOR

Connects the supplied flexible antenna or an optional external aerial adaptor.

9. BATTERY PACK

Rechargeable lithium-Ion battery packs.

10. ACCESSORY CONNECTOR

To connect any HT900 Series radio to an Entel approved audio accessory.

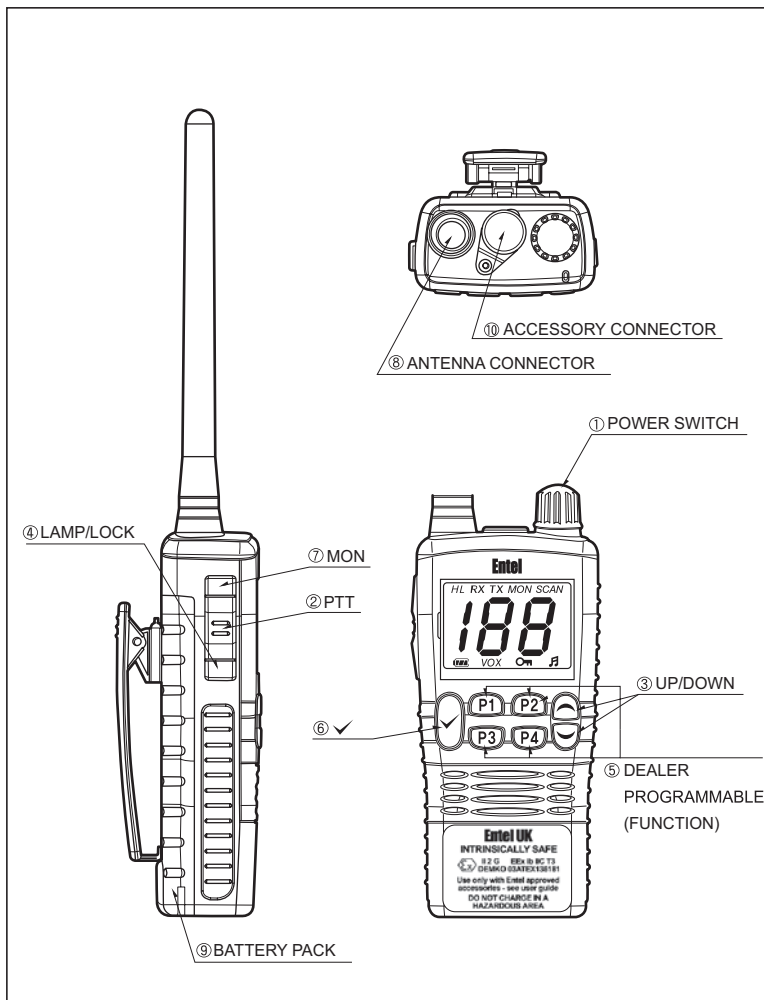

Figure 3. CONTROLS & INDICATORS

1.5 LCD INDICATORS

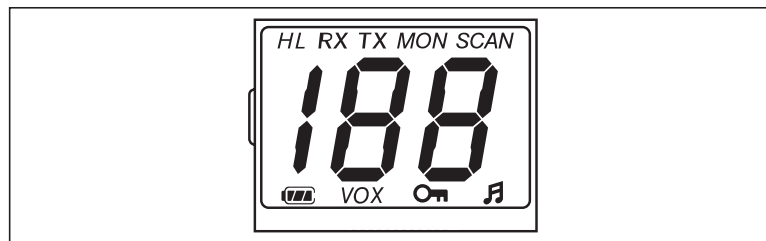

Figure 4. LCD indications

CHANNEL DISPLAY

The operating channel.



Appears when bleep sound is turned on.

H/L

H indicates high power L indicates low power.

SCAN

Appears when scan is activated.

TX

Indicates transmission is in progress.

RX

Indicates reception is in progress.

VOX

Voice operated mode enabled.



The keypad is locked.



The lithium-Ion battery of your transceiver is continually monitored for your convenience and safety.

MON

Indicates CTCSS/DSS disabled on receive allowing monitoring of the channel.

1.6 RECEPTION

1. Turn the transceiver on by rotating the volume control in a clockwise direction. A power on tone is generated after 1 second to indicate the transceiver has passed its self-diagnostic test. Select the desired audio level by further rotating the control clockwise.
After power on, the transceiver will always default to the last channel selected.
2. Select the desired channel using the [UP/DOWN] buttons.
3. When receiving a signal the LED indicator illuminates green, and "RX" is displayed on the LCD.

1.7 TRANSMISSION

1. Perform steps 1 through 3 of RECEPTION.
2. Before transmitting, monitor the channel and make sure it is clear.
3. When receiving a signal, wait until the signal stops before transmitting.
The transceiver cannot transmit and receive simultaneously.
4. Press the [PTT] (push-to-talk) switch to begin your transmission.
To confirm transmission in progress the LED illuminates RED, and TX is displayed on the LCD.
5. Holding the transceiver 2 inches from your mouth speak slowly and clearly into the microphone.
6. When the transmission is finished, release the [PTT] switch.

1.8 ADDITIONAL FEATURES

The HT900 Series incorporates some additional features that can be of positive benefit to your organisation. These features can be set-up and accessed in a number of different ways using any one of the programmable buttons. Please contact your dealer to discuss your exact requirements.

VOICE OPERATED TRANSMIT (VOX)

In VOX mode the transceiver will react to your voice and transmit automatically without you having to press the PTT button.

There is always a slight delay for the electronic switching, therefore starting a transmission with an exaggerated length, throwaway, first word is recommended e.g. "H-e-l-l-o Charlie One do you receive, over".

To enable the VOX feature press the "FCN" button three times.

VOX will flash on the LCD display. As default it is switched off.

To switch this feature on press either the UP or down button to scroll through the levels. When the desired level is selected press the ENTER button to confirm. Level 9 is the most sensitive setting and should be used in low ambient noise environments. Level 1 is least sensitive and should be used in a high ambient noise environment.

Once this feature is enabled in the menu you can turn it on and off by pressing the VOX button located on the front panel. If you press and hold this button you can change the levels.

2.0 OPTIONAL TRICKLE CHARGER-model CCA230

1. Connect the CWC640 AC adaptor to the CCA230 charger pod. The LED status light will illuminate green indicating ready for charge.

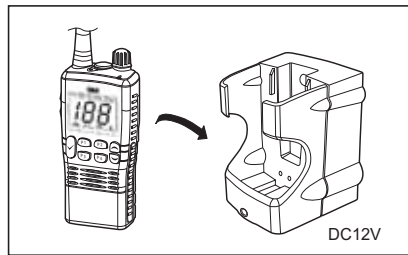

Figure 5. CCA230 Charger pod

2. Turn the transceiver off.
3. Insert the battery pack

into the CCA230 pod, either with or without the transceiver attached. The LED status light changes from green to RED and trickle charge begins.

4. A fully discharged battery pack will take approximately 6 hours to charge, depending on the remaining power condition.

When charge is complete, the LED status light turns green.

Note: The CWC640 AC adaptor can be replaced by the CMC640 12v charger cable. Charge time remains at 6 hours.

2.1 OPTIONAL RAPID CHARGER-model CSA640E

1. Connect the CSA640E to a mains supply (110 to 230V). When switching on, the LED flashes orange briefly to confirm self-diagnostic test complete.

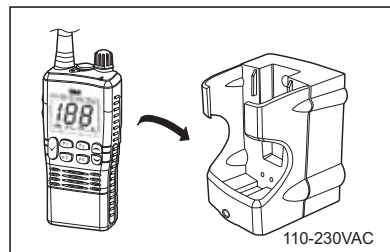

Figure 5-1. OPTIONAL CSA640E
Rapid charger

2. Turn the transceiver off.
3. Insert the battery pack into the CSA640E charger, either with or without the transceiver attached. The LED will illuminate red to indicate rapid charge in progress.
4. Charge time for a fully discharged battery pack will take up to 120 minutes. On completion the LED turns green.

2.2 BATTERY INDICATOR

For your safety and convenience your transceiver continually monitors the battery pack and gives an indication on the LCD:

- 3 Segments : 14hours
- 2 Segments : 1hour
- 1 Segment : 20mins



Figure 6. Battery Indicator

2.3 BATTERY SAFETY

The battery pack of your transceiver contains lithium-Ion cells. This type of battery stores a charge powerful enough to be dangerous if misused or abused, especially when removed from the transceiver. Please observe the following precautions:

DO NOT SHORT BATTERY PACK TERMINALS

Shorting the terminals that power the transceiver can cause sparks, severe over heating, burns, and battery cell damage.

If the short is of sufficient duration, it is possible to melt the battery components. Do not place a loose battery pack on or near a metal surface or objects such as paper clips, keys, tools etc.

When the battery pack is installed on the transceiver, the terminals that transfer current to the transceiver are not exposed.

The terminals that are exposed on the battery pack when it is mounted on the transceiver are charging terminals only and do not constitute a hazard.

DO NOT INCINERATE

Do not dispose of your CNB940E battery in a fire or incinerator. The heat of fire may cause battery cells to explode and/or release dangerous gases.

DISPOSE OF BATTERY PACKS PROPERLY

Lithium-Ion battery packs must be recycled or disposed of properly. For requirements in your area, check with the dealer from whom you purchased your transceiver.

2.4 TROUBLE SHOOTING

TROUBLE SHOOTING CHART		
SYMPTOM	PROBABLE CAUSE	REMEDY
Transceiver not switching on	Battery needs charging Battery is exhausted	Charge the battery pack Replace the battery pack
Cannot change any function	Key lock is switched on	Turn key lock off
LED on CCA640 & CWC640 does not illuminate when charging	Defective battery, CCA640, or CWC640 Dirty terminal contact on CCA640	Contact your dealer Clean contacts with dry clean cloth
Receiving calls from other users outside your radio system	congestion on channel	contact your dealer for new frequency or sub tone assignment
Transceiver transmits without pressing PTT button Buttons seem to work intermittently	VOX has been enabled	Press assigned vox button to switch vox off.

Certification

ATEX approved

Intrinsically Safe

DEMKO 03ATEX136181



E Ex i b II A T3 - 4 Watt version

E Ex i b II B T3 - 3.5 Watt version

E Ex i b II C T3 - 1 Watt version

- ▶ The HT920/980 must always be used within the terms of its certification.
- ▶ Keep HT920/980 away from aggressive substances. If used in a hostile environment, extra protection may be needed.
- ▶ To prevent ignition of hazardous atmospheres, batteries must only be charged or changed in an area known to be non hazardous.
- ▶ No unauthorised repairs are permitted. Details of authorised service centres are available from Entel UK.
- ▶ This equipment is designed and manufactured to protect against other hazards as defined in paragraph 1.2.7 of Annex II of the ATEX Directive 94/9/EC

FOR USA VERSION:-
2.6 SAFETY TRAINING INFORMATION

WARNING.

Your Entel radio generates RF electromagnetic energy during transmit mode. This radio is designed for and classified as "Occupational Use Only", meaning it must be used only during the course of employment by individuals aware of the hazards, and the ways to minimize such hazards. This radio is NOT intended for use by the "General Population" in an uncontrolled environment.

Use only Entel approved accessories. Use of accessories other than those specified may result in RF exposure levels exceeding the FCC requirements for wireless RF exposure.

CAUTION.

To ensure that your exposure to RF electromagnetic energy is within the FCC allowable limits for occupational use, always adhere to the following guidelines:-

- ▶ DO NOT operate the radio without a proper antenna attached, as this may damage the radio and may also cause you to exceed FCC RF exposure limits. A proper antenna is the antenna supplied with this radio by the manufacturer or antenna specifically authorized by the manufacturer for use with this radio.

- ▶ DO NOT transmit for more than 50% of total radio use time ("50% duty cycle"). Transmitting more than 50% of the time can cause FCC RF exposure compliance requirements to be exceeded. The radio is transmitting when the "TX indicator" lights red. You can cause the radio to transmit by pressing the "PTT" switch.

► ALWAYS keep the antenna at least 2.5 cm (1 inch) away from the body when transmitting and only use approved accessories to ensure FCC RF exposure compliance requirements are not exceeded.

To provide the recipients of your transmission the best sound quality, hold the transceiver at least 5 cm (2 inches) from your mouth, and slightly off to one side.

The information listed above provides the user with the information needed to make him or her aware of RF exposure, and what to do to ensure that this radio operates within the FCC RF exposure limits.

Electromagnetic Interference/Compatibility

During transmissions, your Entel radio generates RF energy that can possibly cause interference with other devices or systems.

To avoid such interference, turn off the radio in areas where signs are posted to do so. DO NOT operate the transmitter in areas that are sensitive to electromagnetic radiation such as hospitals, aircraft, and blasting sites.

Occupational/Controlled Use

The radio transmitter is used in situations in which persons are exposed as a consequence of their employment. These persons should be made fully aware of the potential for exposure so they can exercise control over their exposure.

Changes or modifications to this device, not expressly Approved by Entel UK could invalidate your authority to Operate this device under FCC regulations.

2.7 NOTES

Use this page to record important information, such as the serial number of your HT900 Series transceiver, and any of the frequencies and sub-tones programmed by your dealer.

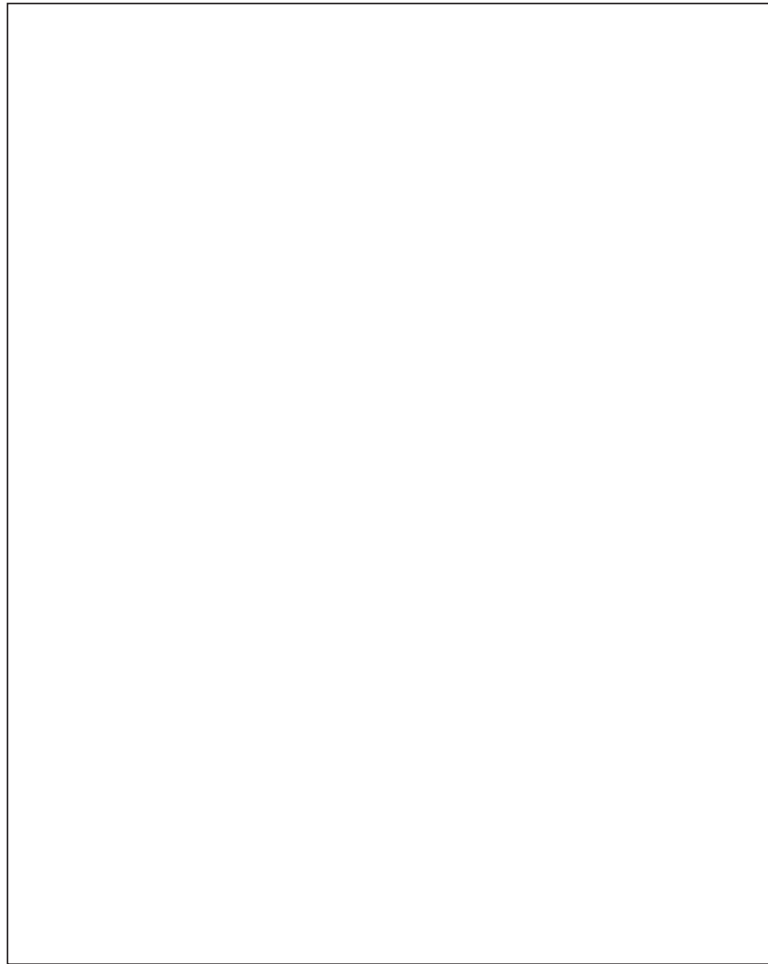
A large, empty rectangular box with a thin black border, intended for recording important information such as the serial number of the transceiver and programmed frequencies and sub-tones.

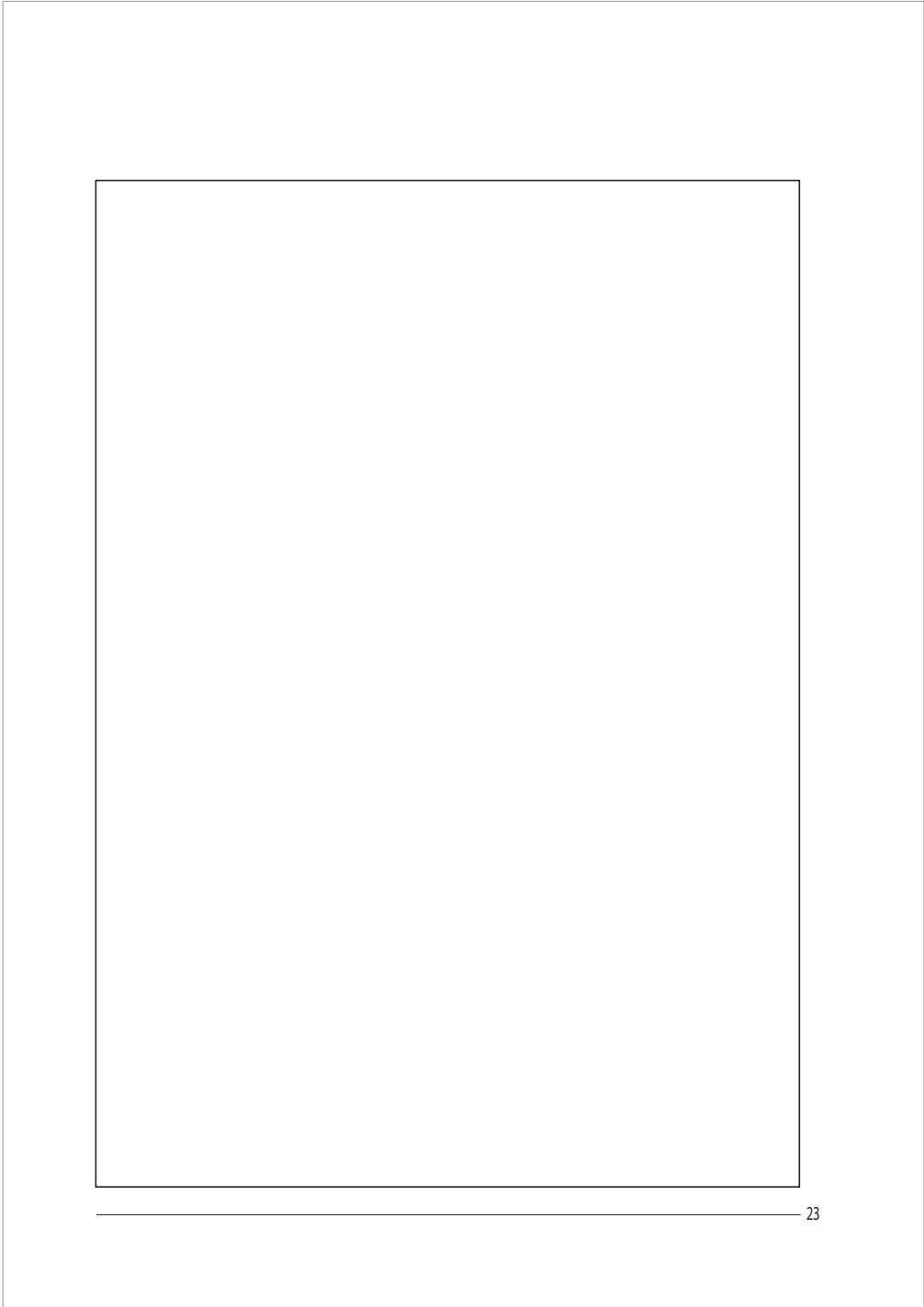

Complete HT Series application guide for land and marine models:-

Model	Land	Marine	VHF	VHF (Low band)	UHF	ATEX (I.S)	USTC (I.S)	Channels	PMR446	GMDSS
HT446	✓	✗	✗	✗	✓	✗	✗	8	✓	✗
HT640	✗	✓	✓	✗	✗	✗	✗	57 Marine	✗	✗
HT710	✓	✗	✗	✓	✗	✗	✗	128	✗	✗
HT720	✓	✗	✓	✗	✗	✗	✗	128	✗	✗
HT780	✓	✓	✗	✗	✓	✗	✗	128	✗	✗
HT820	✓	✗	✓	✗	✗	✗	✓	128	✗	✗
HT840	✗	✓	✓	✗	✗	✗	✓	57 Marine	✗	✗
HT880	✓	✓	✗	✗	✓	✗	✓	128	✗	✗
HT920	✓	✗	✓	✗	✗	✓	✗	128	✗	✗
HT940	✗	✓	✓	✗	✗	✓	✗	57 Marine	✗	✗
HT950	✓	✗	✗	✗	✓	✓	✗	8	✓	✗
HT980	✓	✓	✗	✗	✓	✓	✗	128	✗	✗
HT70	✗	✓	✓	✗	✗	✗	✗	Up to 57 Marine	✗	✓

I.S. = intrinsically safe for hazardous applications

*only for use in Europe

<Intended Country of Use>

- | | | |
|------------------------------|------------------------------|------------------------------|
| <input type="checkbox"/> GER | <input type="checkbox"/> NED | <input type="checkbox"/> ITA |
| <input type="checkbox"/> AUT | <input type="checkbox"/> BEL | <input type="checkbox"/> GRE |
| <input type="checkbox"/> GBR | <input type="checkbox"/> LUX | <input type="checkbox"/> SWE |
| <input type="checkbox"/> IRL | <input type="checkbox"/> ESP | <input type="checkbox"/> DEN |
| <input type="checkbox"/> FRA | <input type="checkbox"/> POR | <input type="checkbox"/> FIN |

CE0891!

Registered Community Design Application 000044375

U.S. Design Patent Pending No. 29/183,829

Copyright and Unregistered Design Right Entel UK 2003.

All rights reserved

Copyright Entel UK Ltd, London